



Yaw Damper System

Installation Manual

83000-63 Rev C



TRUTRAK FLIGHT SYSTEMS

1500 S. Old Missouri Road

Springdale, AR 72764

Ph: 479-751-0250 Fax: 479-751-3397

www.trutrakap.com

Mechanical Installation Considerations

MODULE INSTALLATION

Mounting Considerations

The Yaw Damper module is designed to mount on a vertical bulkhead or horizontal surface in the aircraft, with the bottom flange level with the aircraft, as shown on the first page. Level to the aircraft, installation is very important as the knob on the YD module will only remove a slight discrepancy in leveling. Install the wire connector pointing forward or aft, see installation initial check out for details. Use aircraft installation standards for mounting and support of the YD system.

Wiring Considerations

Use AWG #24 or larger wire for all connections unless otherwise specified. The standard solder pin contacts supplied in the connector kit are compatible with up to AWG #18 wire. In cases where some installations have more than one component sharing a common circuit breaker, sizing and wire gauge is based on, length of wiring and current draw on units. In these cases, a larger gauge wire such as AWG #20 may be needed for power connections. Do not attach any wires to the outside of the YD or route high current wires within six (6) inch of the module. Ensure that routing of the wiring is not exposed to sources of heat, RF or EMI interference. Check that there is ample space for the cabling and mating connectors. Avoid sharp bends in cabling and routing near aircraft control cables.

RFI/EMI considerations

The YD module is shielded and does not generate any appreciable level of electromagnetic interference. Moreover, the servo lines (except for power and ground) are low-current and cannot contribute to RF interference. The servo power and ground lines do have switching currents through them, but so long as there are no parallel runs of servo power and ground lines with such things as poorly-shielded antenna lines or strobe light power lines, there is no need to shield the servo harnesses. The YD module itself has been internally protected from RF interference and has been tested under fairly extreme conditions, such as close proximity to transmitting antennas. However, it is always good practice to insure that such antennas are properly shielded and not routed directly over or under sensitive panel-mounted electronic equipment. Most problems in this area are the result of improper RF shielding on transmitting antennas, microphone cables, and the like.

Servo Installation

The installation information in this section is extremely important and must be **clearly understood** by the installer. Improper servo installation or failure to observe and diagnose installation problems prior to flight can result in extremely serious consequences, **including loss of ability to control the aircraft**. If there are any questions on the part of the installer it is mandatory to resolve these questions **prior to flight** of the aircraft.

Most modern experimental aircraft use push-pull tubes to drive the primary controls. These tubes generally have a total travel of 3" or less; therefore, it is best to connect the autopilot servo to the primary control by the same method. This connection consists of an arm on the servo connected by a push-pull rod to the primary control. Rod-end bearings are required on each end of the push-pull rod. The servo arm **must not** rotate even **near** to the point called OVER CENTER, the point at which the primary aircraft control would **lock up**. Some aircrafts mechanical primary control installations will not allow this to occur and do not need the servo stops. This is a condition that would result from the servo being back driven when the pilot operates the controls, or from the servo itself driving the controls to a stop. To protect against this mechanical stops are supplied with the servos. These stops are drilled so that they can be mounted at different angles as required (18° intervals).

In addition to the proper use of the stop it is important to know the amount of travel on the primary control that the servo can handle. With the push rod connected to the outermost hole (1 ½") the travel on the primary cannot exceed 2 ½", the intermediate hole 2 1/16", and the inner hole 1 5/8".

It is important to note that at the neutral point of the control the SERVO ARM must be PERPENDICULAR to the push rod, and that the stop must be mounted so as to limit travel as near as possible to equal amounts in both directions. In certain factory-designed installations there may be well-proven exceptions.

There will be installations in which space does not permit the use of the stop. When this is done the aircraft's primary control stops must be positive and care must be taken to be sure that at the neutral point the servo arm is perpendicular to the push rod, and that the travel limits of the servo arm are not exceeded.

There are installations in which the travel of the push-pull tube exceeds the allowable 2 ½". For such installations, the drive can be applied to a bell crank at a radius point that moves the desired 2 ½" of maximum allowed travel in the outermost hole of the arm.

When there is no way to have a drive point of less than 2 ½" or when the primary control is cable-driven it is necessary to use the capstan-cable servo drive. When this is done the servo should be mounted so that the 1/16" diameter cable which wraps around the capstan when extended parallel to the primary cable is approximately 3/16" from the primary cable. If the primary control travel does not exceed 5" the cable locking pin will be 180° away from the point at which the cable leaves the capstan. When the primary control is at the neutral point this means the total cable wrap around the capstan is 360°. If the primary control travel is greater than 5" the cable wrap is 720° and the pin is adjacent to the output point when the primary control is at the neutral point.

The cable clamps when properly installed will not slip and thus get loose, but it is desirable to NICO press or swedge a fitting on to the cable so as to provide added assurance that the cable will

not become slack. If the bridle cable is not sufficiently tight there will be lost motion in the autopilot drive. This will result in hunting (oscillation).

Yaw Damper Initial Setup & Checkout

The next step in the installation procedure is to verify electrical operation of the yaw damper. **Before this test, remove the yaw damper module from its mounting location** so that it can be manually tilted. Verify the direction strap is correctly wired on pins 17 and 18 of J501, the 25-pin yaw damper connector. If the unit is to be mounted on the rear side of a bulkhead, connector pointing aft, the strap between pins 17 and 18 of J501 must be **absent**. If the unit is to be mounted on the front side, connector pointing forward, the jumper must be present. Enter the Yaw Damper setup mode in the autopilot controller, advance to and set YD ACTIVITY value to 15. Advance to the MIN AIRSPD field, set the minimum airspeed to 0. MIN airspeed must be set to 0 on the ground to engage the YAW damper.

Having verified the strap, manually center the rudder and then engage the yaw damper by following the correct procedure (see autopilot installation manual) for the autopilot programmer. Position the toggle switch on the YD module in the **GYRO “OFF”** position to set the centering, hold the yaw damper module in the same position it will occupy when mounted on the bulkhead in an approximately level position that stops the servo rotation. Tilt the module to simulate the aircraft banking to the right. The yaw damper should respond by commanding the rudder to move towards the right, and conversely a bank to the left should move the rudder towards the left. If the servo moves in the wrong direction during this test, double-check the correct jumper setting on pins 17 and 18 and if found to be correct, interchange the wires on the yaw damper servo connector (pins 4 and 5 of J401) or at the connector on the yaw damper module (pins 12 and 13 of J501). Re-check the direction after exchanging the wires.

Having verified the correct direction of response to the tilt sensor, secure the yaw damper module to the bulkhead. Re-engage the yaw damper and adjust the leveling potentiometer, the black knob which protrudes from the face of the yaw damper module, to stop the movement of the servo (rudder). The aircraft should be on a level surface (with its “ball” centered) for this adjustment. Once the proper tilt adjustment is done, switch the toggle switch toward “gyro on” and push on the tail to confirm correct servo movement. Rudder must move in direction of empennage direction. Example: Empennage moves away from you, rudder swings way from you.

Once the proper adjustment is done and confirmed, disengage the yaw damper, re-enter the Yaw Damper setup mode, advance to and set YD ACTIVITY value to zero. This insures that the yaw damper adjustments do not complicate the first test flight of the autopilot. Advance to the MIN AIRSPD field, set the minimum airspeed to the desired value for actual flight. This should be an indicated airspeed (in knots) which is safely above the stall but below normal approach or climb out speeds. Make sure that the toggle switch on the Yaw Damper controller is toggled toward GYRO “ON” for flight.

The remaining adjustments relate to the dynamics of flight.

First Flight Yaw Damper

The Yaw Damper system requires adjustment of the Yaw Damper parameters. With the autopilot disengaged, level the aircraft and hand-fly the aircraft in still air. With your feet off the rudder pedals, confirm that the ball is centered. If the ball is NOT centered, correct the aircraft out of trim condition before proceeding. Press the appropriate button to engage the Yaw Damper. Then enter the YD setup screen. Cycle through the settings already completed, until YD LEVELING is shown on the display. Centering is adjustable from -8 to 8 and has enough authority to move the ball approximately one and one half times the width of the ball in either direction. (Coarse adjustment was made using the potentiometer in the yaw damper module during the earlier Initial Checkout Procedure.) Adjust the centering so that the ball is centered. If unable to center the ball in flight, confirm Initial check out setting. Once the YD LEVELING has been set, advance to the next setup screen.

The YD ACTIVITY determines how aggressively the yaw damper responds to yaw disturbances. Yaw damper activity can range from 0 (off) to 12 (extremely aggressive). For this setting, it is best to find light to moderate turbulence so the effects can be properly observed. Having found suitable conditions, gradually increase the value of YD ACTIVITY in order to obtain an appropriate level of response to yaw disturbances. Too high a value will result in rapid oscillation, while too low a value will essentially disable the quick response of the yaw damper to turbulence. Within the acceptable range of operation, there is still room to account for personal preferences. So long as the yaw damper's YD ACTIVITY value is not so high as to cause oscillation, the response is simply set according to preference and comfort. Once the YD ACTIVITY has been set, exit the setup mode.

With the DII Series autopilot Yaw Damper installations only. The two potentiometers that are needed (see schematic) serve the function of the Yaw activity and the in-flight ball centering.

The normal operation of the autopilot will turn the yaw damper on any time the autopilot is engaged, and the yaw damper will stay on after the autopilot is disengaged. During final approach and the diminishing of the airspeed below the MIN AIRSPD setting, the yaw damper will automatically disengage. To disengage the yaw damper prior to that point, simply use the YD or TRK button to toggle the yaw damper off. When the autopilot is in the Off mode, the YD or TRK button acts as a yaw damper on/off toggle function and the display will indicate YD ON or YD OFF.

This concludes the in-flight setup of the TruTrak Yaw Damper.

Electrical Pin-Out

The table below provides a brief explanation of each pin function on the 25-pin connector P501.

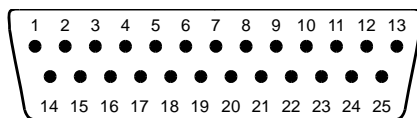

25-Pin Connector P501

P101 Pin	Function	Notes
1	Power. Connects to autopilot master or pitch servo power line from programmer.	+12 or +28 V
2	Ground. Connect to aircraft ground.	Aircraft ground
3	Yaw Damper Activity. A signal from the autopilot which sets the amount of response the yaw damper exhibits to azimuth disturbances and “ball” deflection.	0 to +5v at YD For testing only
4	Yaw Damper Leveling. A signal from the autopilot which is used for fine adjustment of the “ball” in a yaw damper.	0 to +5v at YD For testing only
5	Torque Control. Servo torque control output to servo pin 6	+5v at servo pin 6 For testing only
6	No Connection. Reserved for future expansion.	
7	No Connection. Reserved for future expansion.	
8	Yaw Damper Activate. A signal from the autopilot which turns on the yaw damper function.	0 to engaged at YD For testing only
9	No Connection. Reserved for future expansion.	
10	PH1P. Servo drive line output to servo pin 3.	
11	PH1N. Servo drive line output to servo pin 2.	
12	PH2N. Servo drive line output to servo pin 4.	Swap to reverse
13	PH2P. Servo drive line output to servo pin 5.	Servo direction
14	Power. Power connection to pitch servo pin 1	Connected internally to pin 1
15	Ground. Ground connection to pitch servo pin 9.	Connected internally to pin 2
16	No Connection. Reserved for future expansion.	
17	Jumper to pin 18 for mounting with the connector forward	
18	Jumper to pin 17 for mounting with the connector forward	
19	No Connection. Reserved for future expansion.	
20	No Connection. Reserved for future expansion.	
21	No Connection. Reserved for future expansion.	
22	No Connection. Reserved for future expansion.	
23	No Connection. Reserved for future expansion.	
24	No Connection. Reserved for future expansion.	
25	No Connection. Reserved for future expansion.	

Sorcerer Installation

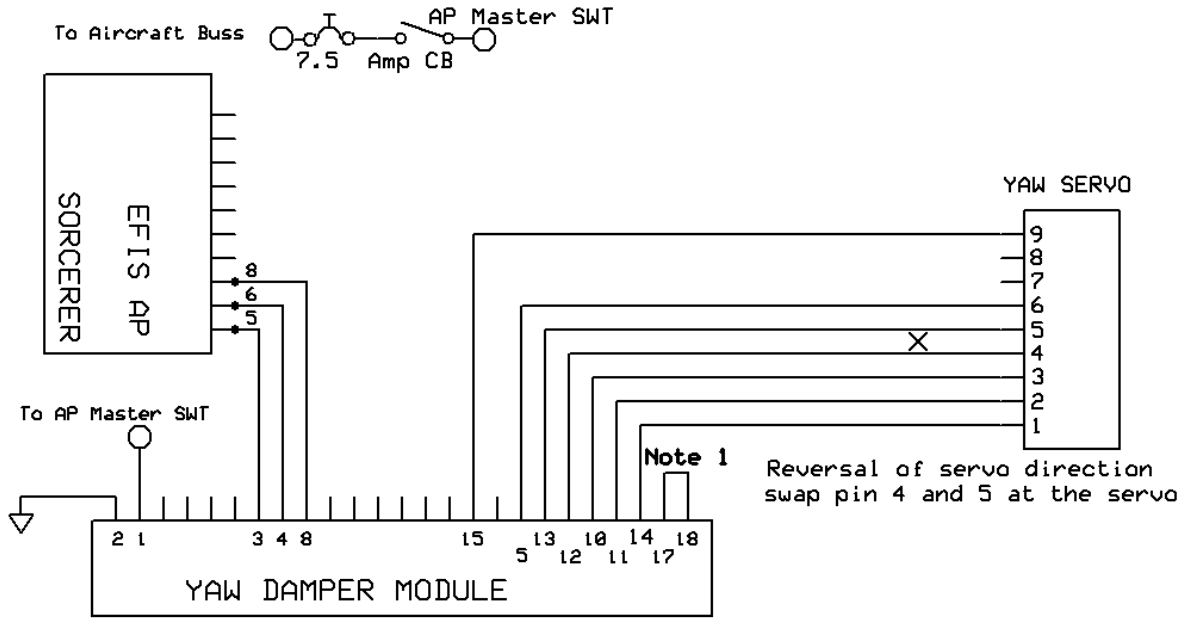

Note 1: Yaw Damper unit must be mounted on a vertical transverse bulkhead. Jumper is installed only if module is mounted on bulkhead front side.

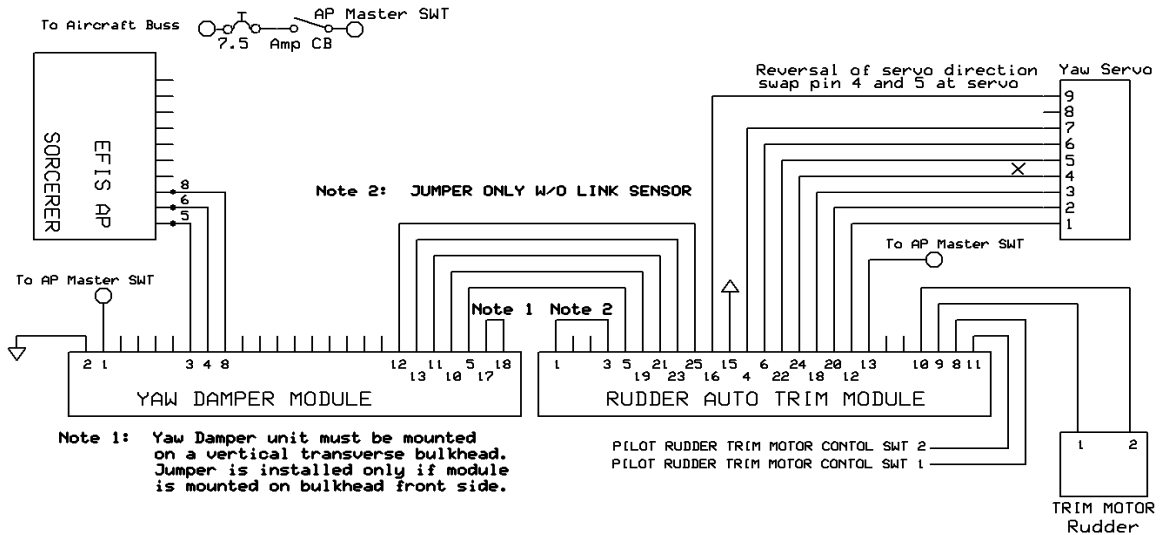

Sorcerer with rudder trim

DII installation

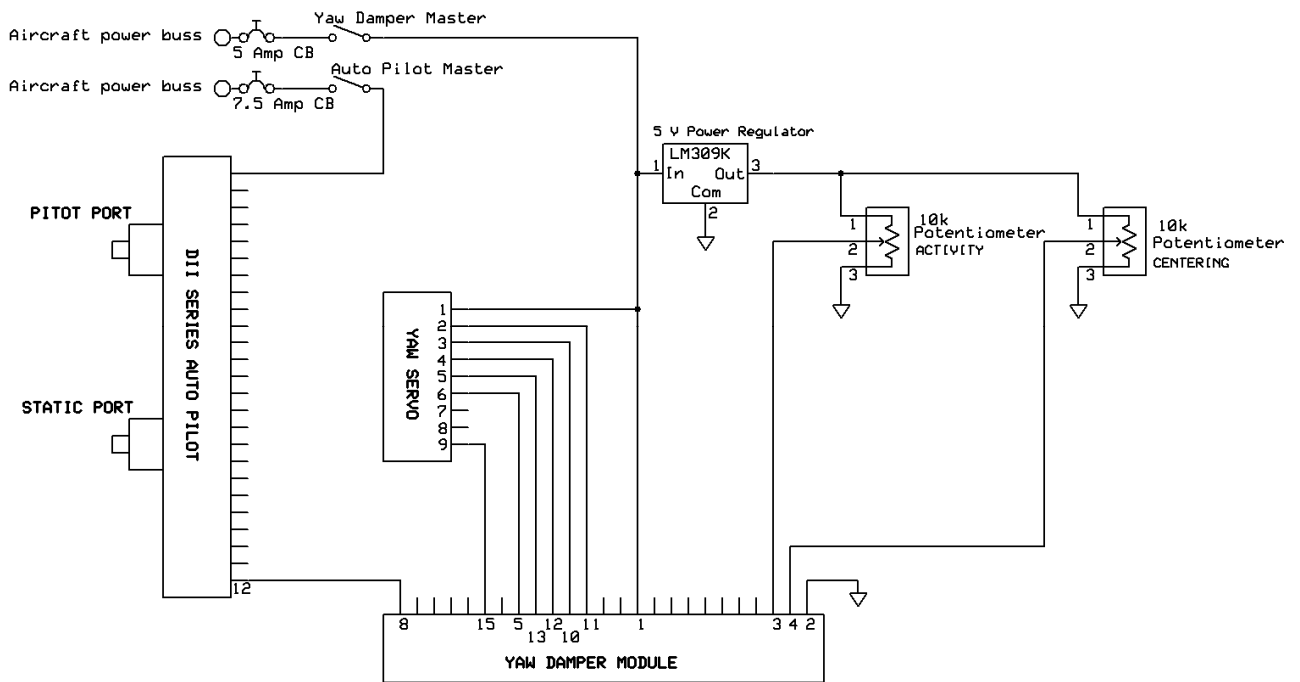

Stand alone installation

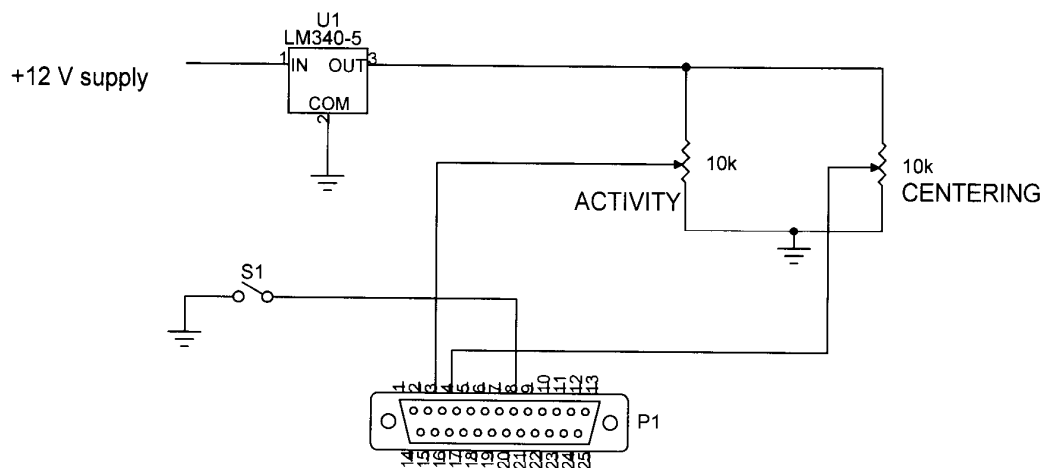

NOTE: OTHER YD CONNECTIONS
(SERVO, ETC) NOT SHOWN.
SEE YD INSTALL MANUAL.

Trouble Shooting

Problem	Cause	Corrective Action
Yaw Servo will not move and is quiet	No aircraft voltage and /or engage signal to Yaw module	Correct power, ground, and / or Engage wiring
Yaw servo will not move but there is clicking	No aircraft voltage and /or torque signal to Yaw servo	Correct power & ground. Check @5 voltage at pin 6 at servo Yaw engaged
Rudder moves in wrong direction	Module strap or servo wires incorrect	Correct wire strap or servo wires per installation instructions
Rudder does not move when tail pushed	Gyro switch not in correct position	Confirm gyro switch in “ON” position
Unable to center ball in flight	Ground centering procedure incorrect	Perform centering procedure per Initial Setup instructions

Warranty On TruTrak Flight Systems Products

We here at TruTrak Flight Systems know how important it is to feel as though the customer is purchasing a product that the manufacturer is going to stand behind. For this reason we want offer more than the basic one year warranty that is standard to this industry. The warranty on all TruTrak products will be three years from the date of purchase. Abuse and misuse of a product are not covered under this warranty. Modification to a product may void the warranty, as well as carry a penalty when upgrading to another product. This three year warranty will be for all products except the Pictorial Turn & Bank, which will continue to have a warranty of one year from the date of purchase.

TruTrak Flight Systems No Penalty Upgrade Policy

As the product line continues to grow, it becomes increasingly difficult to maintain a simple upgrade policy. We do want to reward our repeat customers by allowing a lower cost upgrade from one system to another; however we are not able to offer this across the board on all products. If you are considering an upgrade, please call and we will give you a quote on what this would cost. Many products that we sell today are upgradeable for only the difference in system price. Because we continually strive to have the most up to date products possible, we occasionally have to discontinue products. We will continue to offer discounted upgrades even for our discontinued products.



RETURN MERCHANDISE POLICY AND PROCEDURE

- Under no circumstances should products be returned to TruTrak without first obtaining a Return of Merchandise Authorization number (RMA #) from TruTrak. An RMA# may be obtained by contacting us at 866-878-8725.
- Products that do not have an RMA # will not be processed.
- Please include documentation stating the reason for the return and describing any symptoms, failure modes, suspected causes of damage, diagnostics performed, data collected, etc.
- Product(s) should be packaged in their original shipping containers. In lieu of this, they should be very carefully packaged in containers suitable to protect them during transit. Note that damage caused during shipping will not be repaired under warranty.
- The outside of the box must be clearly marked with the RMA # issued by TruTrak and the RMA # must also be noted on the return documents.
- Products will be returned to the customer at no charge via FedEx Ground or UPS Ground. If customer requests expedited shipping (2nd Day or Overnight) they will be charged the shipping cost and must supply a credit card number.

INTERNATIONAL SHIPMENTS:

- TruTrak sends all International shipments with an insurance value on all products. TruTrak pays for shipping only. The customer is responsible for any and all additional fees, duties, taxes associated with the shipment.
- When sending products to TruTrak for repair or otherwise please be advised that the customer is responsible for all charges and fees associated with shipment. For your protection, items should be insured for the full value.
- TruTrak states on all product returns “WARRANTY REPAIR AT NO CHARGE TO CUSTOMER. A COMMERCIAL INVOICE VALUE OF \$___ GIVEN FOR INSURANCE PURPOSES ONLY”

Please keep in mind that your government or another entity in your country may impose a charge for custom and/or brokerage fees, duties and taxes on items received from the US. These charges do not originate from our company nor do we benefit from them in any way. You are responsible for payment of all custom and brokerage fees, duties and taxes that may be imposed when these goods are imported into your country.

- Send ALL return shipments to:

TruTrak Flight Systems, Inc., 1500 South Old Missouri Road, Springdale, AR 72764 USA
Attention: Returns Dept. RMA# _____

**TruTrak Flight Systems, Inc.
1500 S. Old Missouri Rd.
Springdale AR 72764**

**(479) 751-0250
FAX (479) 751-3397**

www.trutrakap.com